

Thank you for purchasing the Screen Technics Electricinema 235 Projection Screen.

It is important to read the instructions thoroughly before attempting to install and use this product, as incorrect commissioning of the screen may result in damage to the unit.

DESCRIPTION

The Electricinema 235 is an in-ceiling screen box solution with a motorised projection screen in Cinemascope 2.35:1 format – which has motorised side masking that, converts the image to 16:9 Widescreen format.

It comes in an MDF enclosure and is designed to sit above the ceiling line in the home theatre. Having a fully paint finished underside with ceiling edge trims, for a single trade install.

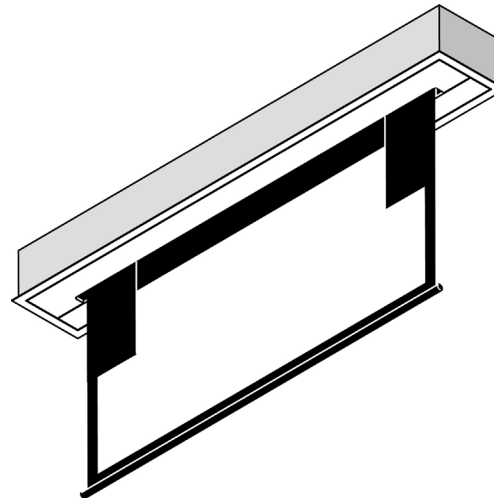
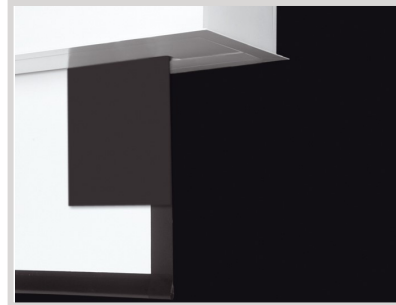

INSTALLATION

STEP 1. The screen box is constructed in 18mm E-Zero MDF board and as such can be used to fit any brackets you may care to utilise, by screwing straight into the box itself, being careful not to penetrate into the internal area, and using the supplied corner captive nuts and eye-bolts to support the screen by chain and turnbuckle from a suitable structure above.

STEP 2. There are 6 x 5/16 Whitworth captive nuts along the top of the box, eyebolts supplied, and we recommend that 6 separate chains are used and that the structure you choose to mount from is secure enough for the job.

STEP 3. Be aware that the unit comes with 3 separate iConnect Motor Controllers that are required to drive the 3 motors, being the Screen, the Side Masking and finally a third motor that moves the masking towards the screen to reduce visible gaps between the screen and the masking. These motor controllers do not fit within the screen box, but are external to the unit. Place these in an accessible position.

STEP 4. There are multiple lengths of power cable exiting the left hand side of the box and it is highly recommended that this cable is left loosely bundled along side the box, so that at a latter date, if the interior chassis of the unit requires removal for servicing, you will have enough slack in the power cords to lower the unit and pull through the side cord exit of the box.

Before you motor down the screen for the first time...Warning

STEP 5. Now you have the unit installed in the ceiling open the two access doors and inspect the transport packaging that now requires removal.

The main screen has been wrapped in brown paper and the side making has been taped to the wrapped main screen.

Remove the masking tape that holds the masking to the screen, freeing the masking for downwards travel.

STEP 6. Now remove the tape on the brown paper that wraps the main screen and carefully motor the screen down (please refer to Control Equipment notes below to achieve this) while applying downward pressure to the brown paper, assisting its removal as the screen descends. Once the paper is removed you should be looking at both screen and masking being free to travel independently.

Continued Over.../

CONTROL EQUIPMENT

The Electricinema 235 utilises three iConnect Motor Controllers that have been specifically programmed to work in unison. They are all controlled by IR, with a 300mm and 2000mm long lead and sensor supplied in the kit, along with a two channel hand held transmitter. The three power leads exiting the screen box left hand side have been labelled to suit the individual iConnect controllers. Please ensure the correct leads are plugged into the motor controllers, as each unit performs a different function.



The 3 x iConnect Motor Controllers are labelled as follows:

1. Screen - which is designed to control the screen surface - IR Channel One
2. Masking - which is designed to control the masking up & down - IR Channel Two
3. Motor - which is designed to work in a delayed action with the masking motor - Channel Two



Channel One - Controls the main projection screen up and down.

Channel Two - Controls the masking up and down, and then the masking moves to lay against screen surface, on a delayed action.

The use of momentary contacts for control is possible, with a separate pair of momentary contacts for the main screen surface (replicating IR Channel One) and another pair of momentary contacts, parallel wired into the two masking motor controllers (replicating IR Channel Two).

NB: iConnect motor controllers 2 and 3 must be controlled together or damage to the screen surface may result.

MASKING TRACKING ADJUSTMENT:

Due to temperature and humidity the masking material may expand or contract a small amount whilst the projection and masking material acclimatise to the installation location.

This may cause the masking to marginally track in a left or right direction when the masking is moving up or down.

To fix the tracking issue:

1. Roll Main projection surface down.
2. Roll masking down

3. Note which direction the masking is tracking (Left or Right).
4. Open the door covering the mechanism
5. Using a small piece of masking tape, (10mm - 15mm piece) and place the tape on the back of the masking roller opposite to the direction of the masking movement
6. Roll masking back up and confirm that masking is straight.
7. You may have to add tape or remove depending on how much the masking is moving

LIMIT ADJUSTMENT

The following instructions are for the adjustment of the limit switches that alter the upper and lower stop positions on Electricinema 235 Projection Screen only

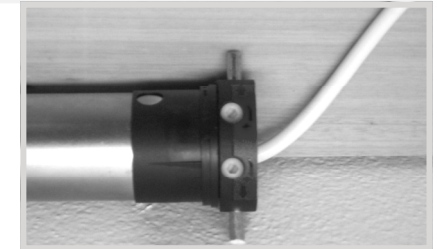

WHERE ARE THE LIMIT SWITCHES?

Left hand side of the screen box, accessed through the 2 bottom doors, look up and you will see 3 sets of limit adjustment Allen Key type switches.

Do not adjust the limit at the front of the box, this being the black steel tube that has wire cable wrapped around it. It is not adjustable and to do so will cause damage to the unit and void any warranty.

WHICH SWITCH IS FOR WHAT?

Inspect the switches and identify the lower motor that controls the screen surface, now look above this to the motor that controls the masking up & down. These are the two sets of limits you may need to adjust, again do not adjust the limit at the front of the box, this being the black steel tube that has wire cable wrapped around it. It is not adjustable and to do so will cause damage to the unit and void any warranty.

WHAT TOOLS DO I NEED?

Either the limit setting tool (supplied), a narrow tip screw driver (less than 4mm) or a 4mm Allen Key

WHICH WAY DO I TURN THE SWITCH?

Either Clockwise always increases the amount of rotation (travel) of the motor.

Anti-clockwise always reduces the amount of rotation (travel) of the motor.

So pick the switch responsible for the limit position, up or down. Clockwise turning of the switch will always let the motor travel further in that direction. Anti-clockwise turning of the switch will lessen the amount of travel in that direction.

CAN I ADJUST THE SWITCH WHILE THE SCREEN IS SITTING ON THE LIMIT - I.E. FULLY UP OR DOWN?

Clockwise adjustment? - YES. But it is better to back the screen away from the limit and then adjust.

Anti-clockwise adjustment? - NO you will damage the micro switch if you turn it anti-clockwise while the screen is sitting on the limit. Never attempt this. You must back the screen away from the limit before adjustment.

After adjustment you will need to run the screen up and down to pick up the new limit.

WILL I VOID THE PRODUCT WARRANTY IF I DAMAGE THE SCREEN WHILST MAKING THESE ADJUSTMENTS?

Yes.

BEWARE

Rollers screens have a finite amount of leader, the standard being 300mm.
If you order a custom leader length then that becomes the finite amount.

DO NOT ADJUST THE BOTTOM LIMIT SO AS TO EXPOSE MORE THAN THIS FINITE AMOUNT

If you do you will:

Experience poor layflat of the surface which may bring complaints from your customer.

Weaken the hold of the surface on the roller and, one day, the surface will be on the floor.

THIS IS NOT COVERED UNDER WARRANTY

Should you have any questions regarding the installation of our products, please call our sales desk on +61 2 4869 2100 for assistance