

**NOTES:**

- Allows Interfit Projector Bracket to be mounted to a 50mm truss
- Supplied with M8 U-Bolts
- 1425001B - Black
- 425001W - White

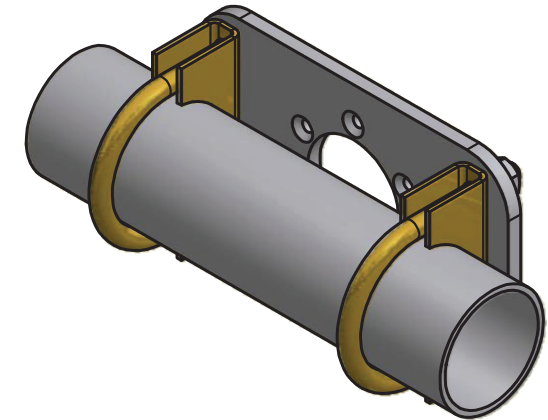
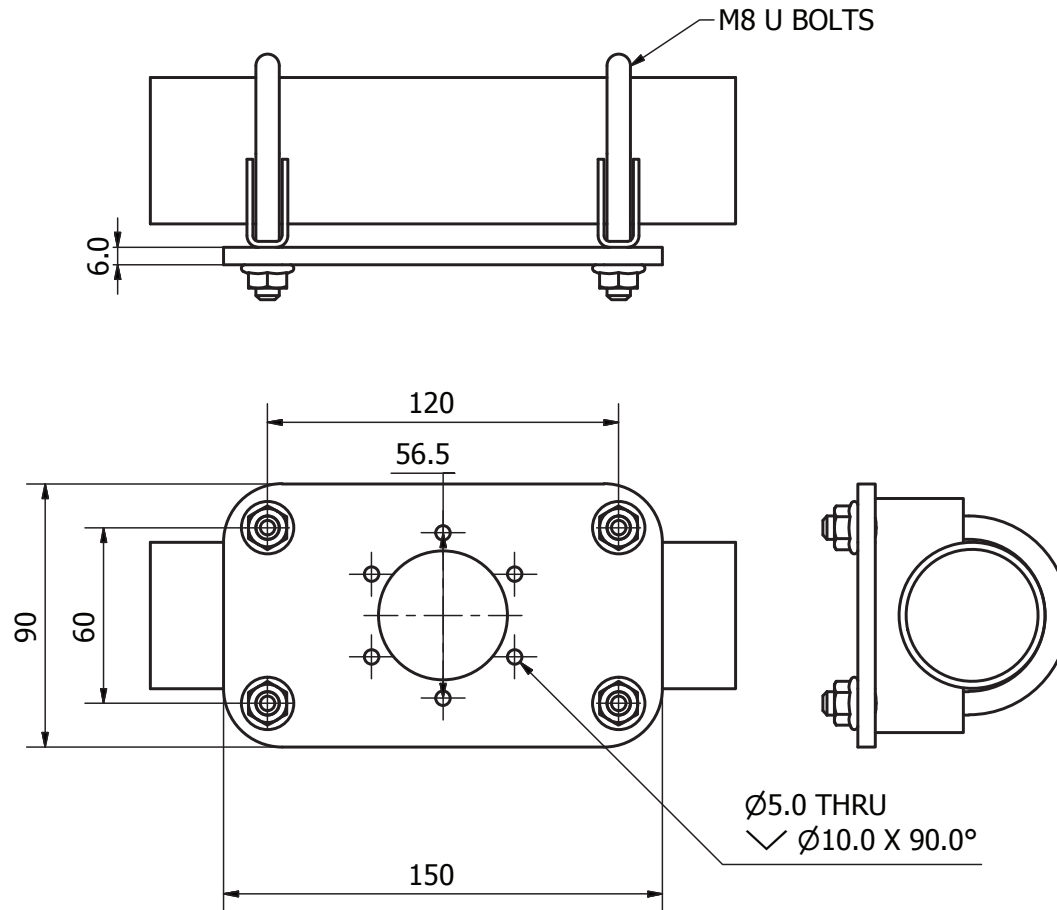

Manufacturing tolerance +/- 5mm  
All dimensions are in (mm)  
If installed in ceiling always allow for removal for servicing.

The Concept, Design and Details in this drawing are the property of Screen Technics with whom the copyright resides. They may not be reproduced without written permission of Screen Technics.

Date	Rev
16/07/2019	2

AUSTRALIA

22-24 Suttor Road  
Moss Vale NSW 2577  
+61 2 4869 2100

screeentechnics.com.au • info@screeentechnics.com.au

NEW ZEALAND

44 Mahana Road  
Te Rapa, Hamilton  
+0800 022 821