



ElectriCinema (Australia) Screen Box

To suit ElectriCinema - Type A

SIZES 72" TO 100"

In ceiling enclosure manufactured from E Zero MDF to allow installation of projection screen above the ceiling line.



Market Segments:



Education



Corporate



Boardroom

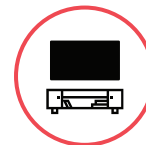

Home
Entertainment

Benefits include:

- Utilising E Zero MDF
- Underside finished in low VOC 2pk white
- Includes internal power junction for easy and complete AV integration
- Integrated power junction box for electrical connection
- Universal bracketing system for the screen
- Can be pre-fitted during the building construction stage
- Pre-wiring facility
- Maintenance access door
- Single trade installation



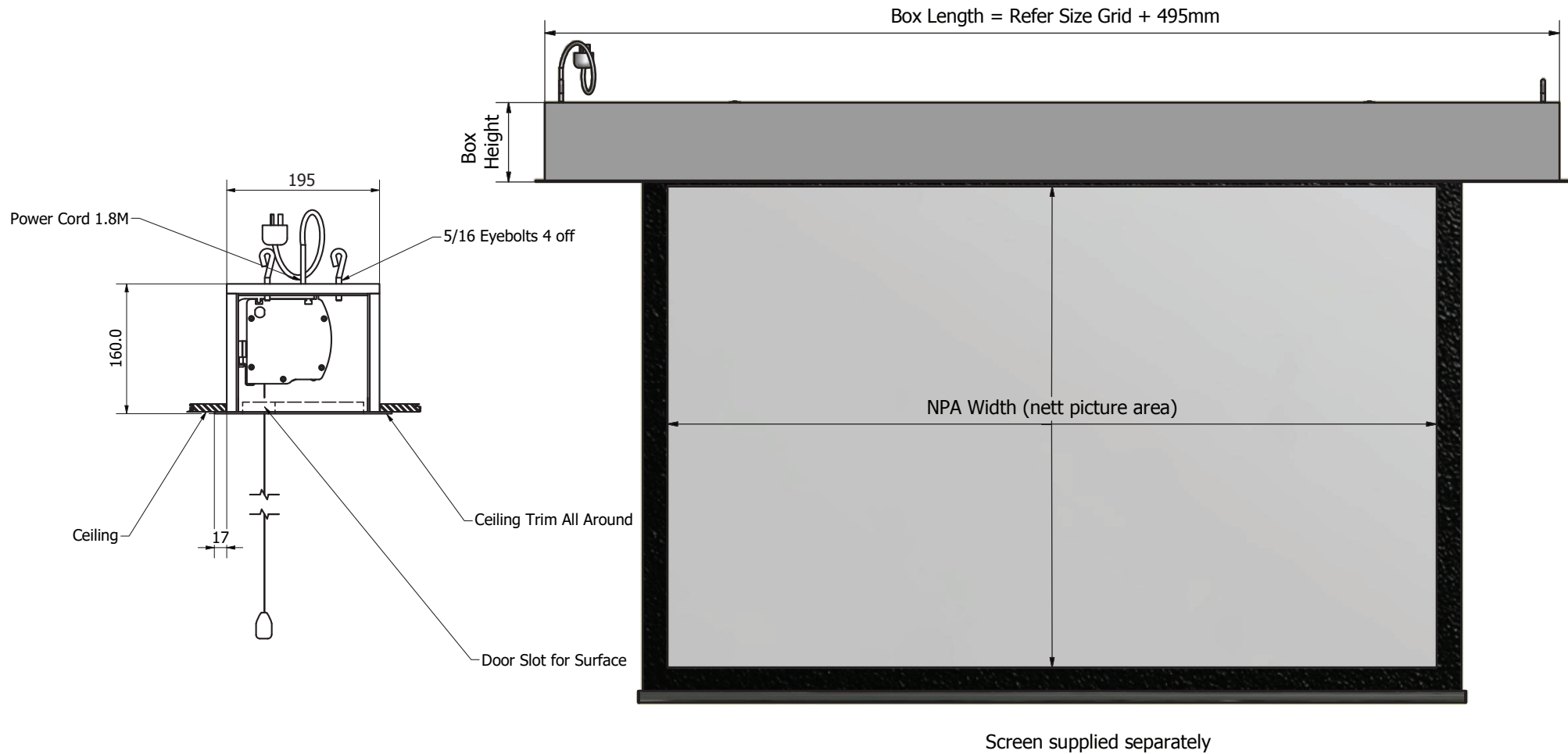

Manufacturing tolerance +/- 5mm. All dimensions are in (mm).
When installed always allow extra cable length for removal of screen.

The Concept, Design and Details in this drawing are the property of Screen Technics with whom the copyright resides. They may not be reproduced without written permission of Screen Technics.

Date
18/11/2019

Rev
04

Product Features

DESCRIPTION:

In-Ceiling installation with power junction and brackets system

BOX:

E0 MDF Construction with fully painted Low VOC 2 pack white underside & ceiling edge covers for easy install. Custom colours available

SCREEN:

Suitable only for ElectriCinema Range of Screens

INSTALLATION:

Utilising 5/16 BSW threaded holes with either brooker rod or eye bolts to suitable structure

BRACKETS:

Utilises brackets supplied with ElectriCinema Screen

SIZES:

As shown - Custom Sizes & Formats available upon request. - Also Side Tension Screens in Type B & C Style

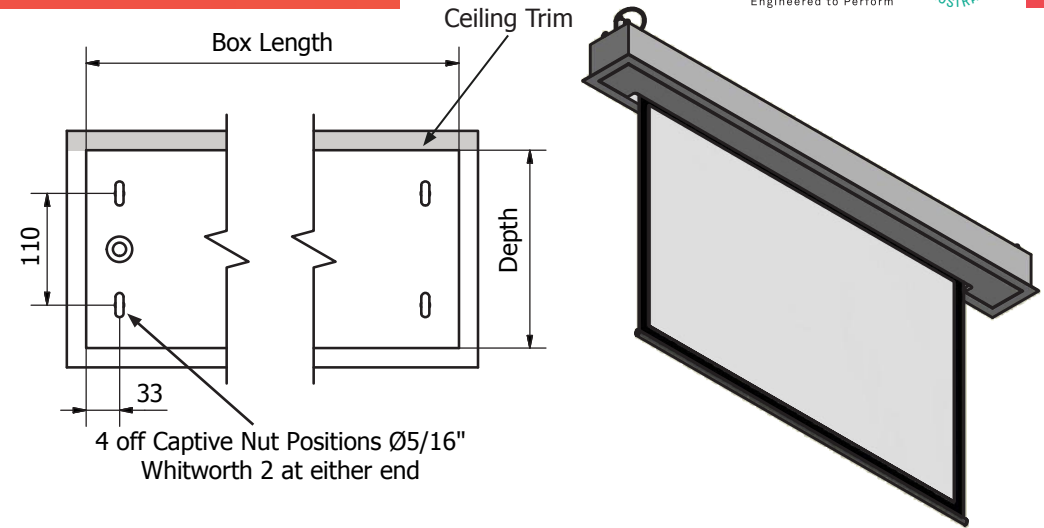

ITEM NO	INCH DIAGONAL	IMAGE SIZE mm	FORMAT	BOX LENGTH mm	BOX HEIGHT mm	BOX DEPTH mm	WEIGHT kg
EB607219-A	72"	1100 x 1465	Video 4:3	1960	160	195	28.0
EB608419-A	84"	1280 x 1705	Video 4:3	2200	160	195	30.0
EB609619-A	96"	1465 x 1950	Video 4:3	2445	160	195	32.0
EB610019-A	100"	1525 x 2035	Video 4:3	2530	160	195	33.0
EB607229-A	72"	895 x 1595	HDTV 16:9	2090	160	195	28.0
EB608429-A	84"	1045 x 1860	HDTV 16:9	2355	160	195	30.0
EB609229-A	92"	1145 x 2035	HDTV 16:9	2530	160	195	33.0
EB609629-A	96"	1195 x 2125	HDTV 16:9	2620	160	195	34.0
EB610029-A	100"	1245 x 2215	HDTV 16:9	2710	160	195	35.0
EB607269-A	72"	970 x 1550	16:10	2045	160	195	28.0
EB608469-A	84"	1130 x 1810	16:10	2305	160	195	30.0
EB609269-A	92"	1240 x 1980	16:10	2475	160	195	32.0
EB609669-A	96"	1295 x 2070	16:10	2565	160	195	33.0
EB610069-A	100"	1345 x 2155	16:10	2650	160	195	35.0

ARCHITECTS SPECIFICATION

The screen box shall be an Australian made Screen Technics ElectriCinema Type A model _____constructed of E0 MDF and shall be located where indicated on the plans. Installation shall be done in accordance with the manufacturer's instructions



Manufacturing tolerance +/- 5mm. All dimensions are in (mm).
When installed always allow extra cable length for removal of screen.

AUSTRALIA

22-24 Suttor Road
Moss Vale NSW 2577
+61 2 4869 2100

NEW ZEALAND

44 Mahana Road
Te Rapa, Hamilton
+0800 022 821

screeentechnics.com.au • info@screeentechnics.com.au