



ElectriCinema (New Zealand) Screen Box

To suit ElectriCinema - Type B

SIZES 110" TO 150"

In ceiling enclosure manufactured from E Zero MDF to allow installation of projection screen above the ceiling line.



Market Segments:



Education



Corporate



Boardroom

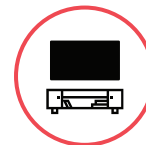

Home
Entertainment

Benefits include:

- Utilising E Zero MDF
- Underside finished in low VOC 2pk white
- Includes internal power junction for easy and complete AV integration
- Integrated power junction box for electrical connection
- Universal bracketing system for the screen
- Can be pre-fitted during the building construction stage
- Pre-wiring facility
- Maintenance access door
- Single trade installation



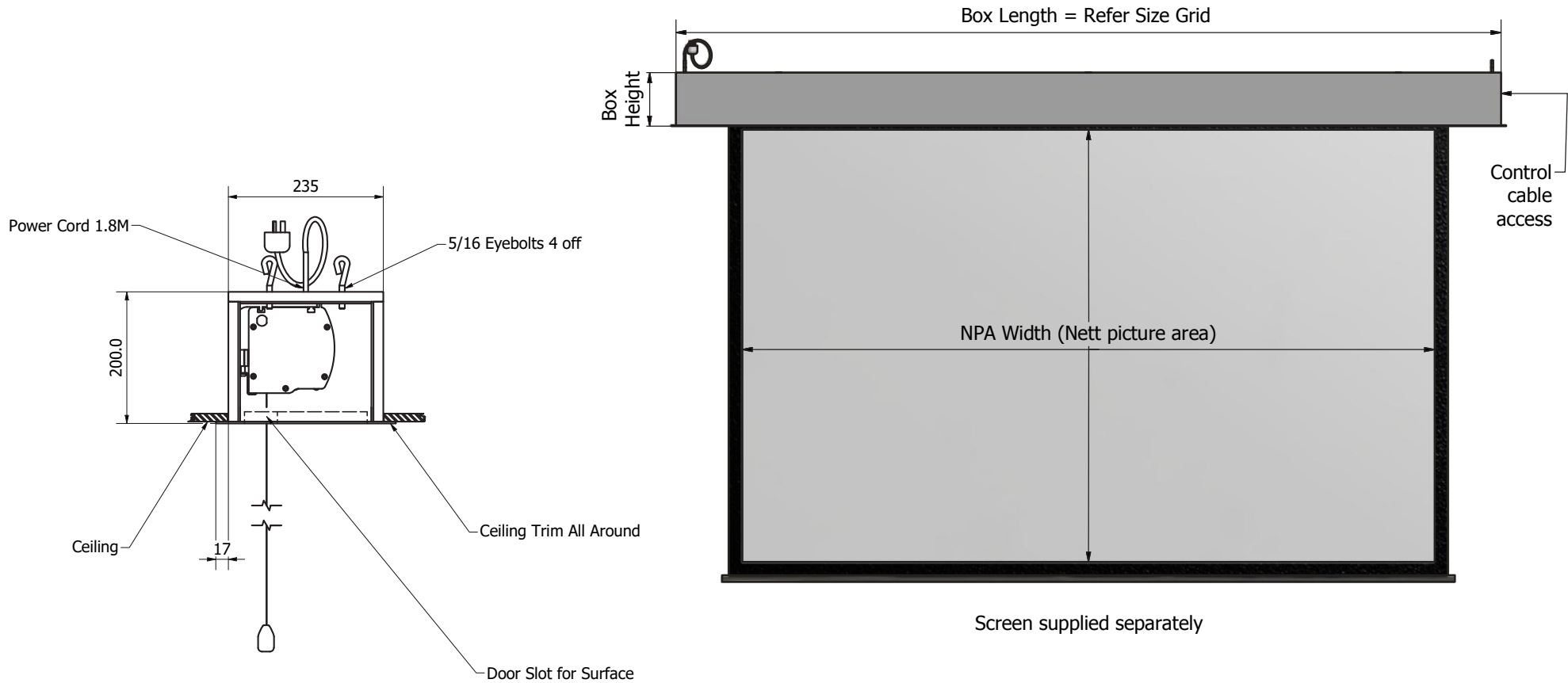

Manufacturing tolerance +/- 5mm. All dimensions are in (mm).
If installed in ceiling always allow for removal for servicing.

The Concept, Design and Details in this drawing are the property of Screen Technics with whom the copyright resides. They may not be reproduced without written permission of Screen Technics.

Date
04/11/2019

Rev
03

Product Features

DESCRIPTION:

In-Ceiling installation with power junction and brackets system

BOX:

MDF Construction with fully painted Low VOC 2 pack white underside & ceiling edge covers for easy install. Custom colours available.

SCREEN:

Suitable only for ElectriCinema Range of Screens

INSTALLATION:

Utilising 5/16 BSW threaded holes with either brooker rod or eye bolts to suitable structure.

BRACKETS:

Utilises brackets supplied with ElectriCinema Screen

SIZES:

Custom Sizes & Formats available upon request

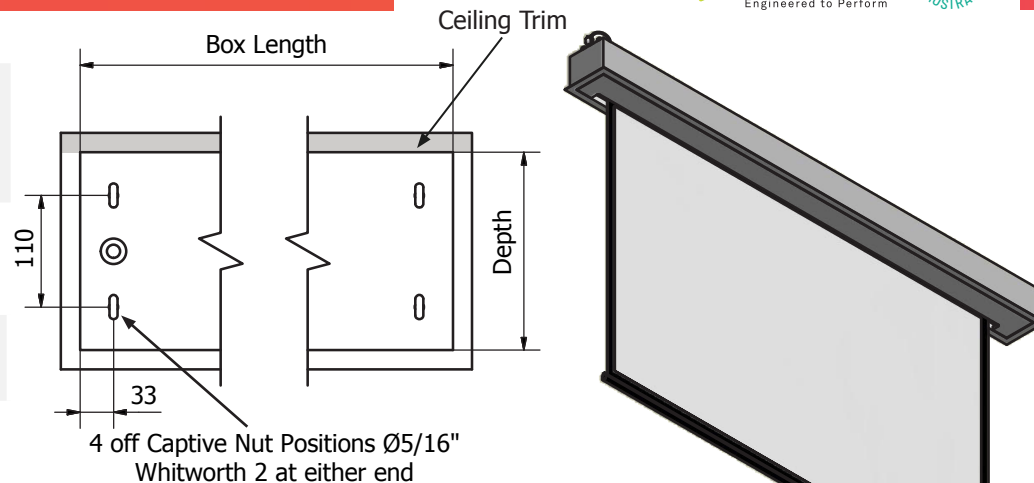

MODEL NUMBER	SUIT	WEIGHT (kg)	DIMENSIONS (mm)		
			L	W	H
EB60009-5	0611519-B 0611029-B 0611069-B 0612019-B	46	2935	235	200
EB60009-6	0611529-B 0612029-B 0612069-B 0613019-B	48	3150	235	200
EB60009-7	0613029-B 0631069-B	51	3375	235	200
EB60009-8	0614019-BR 0614069-BR	57	3660	235	200
EB60009-9	0614029-BR 0615019-BR 0615069-BR 0615029-BR	62	3960	235	200

ARCHITECTS SPECIFICATION

The screen box shall be an Australian made Screen Technics ElectriCinema Type B model _____constructed of MDF and shall be located where indicated on the plans. Installation shall be done in accordance with the manufacturer's instructions



Manufacturing tolerance +/- 5mm. All dimensions are in (mm).
If installed in ceiling always allow for removal for servicing.

AUSTRALIA

22-24 Suttor Road

Moss Vale NSW 2577

+61 2 4869 2100

screeentechnics.com.au • info@screeentechnics.com.au

NEW ZEALAND

44 Mahana Road

Te Rapa, Hamilton

0800 022 821