



ElectriCinema (Australia) Screen Box

To suit ElectriCinema - Type B

SIZES 110" TO 150"

In ceiling enclosure manufactured from E Zero MDF to allow installation of projection screen above the ceiling line.



Market Segments:



Education



Corporate



Boardroom

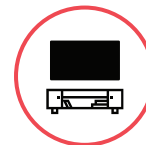

Home
Entertainment

Benefits include:

- Utilising E Zero MDF
- Underside finished in low VOC 2pk white
- Includes internal power junction for easy and complete AV integration
- Integrated power junction box for electrical connection
- Universal bracketing system for the screen
- Can be pre-fitted during the building construction stage
- Pre-wiring facility
- Maintenance access door
- Single trade installation



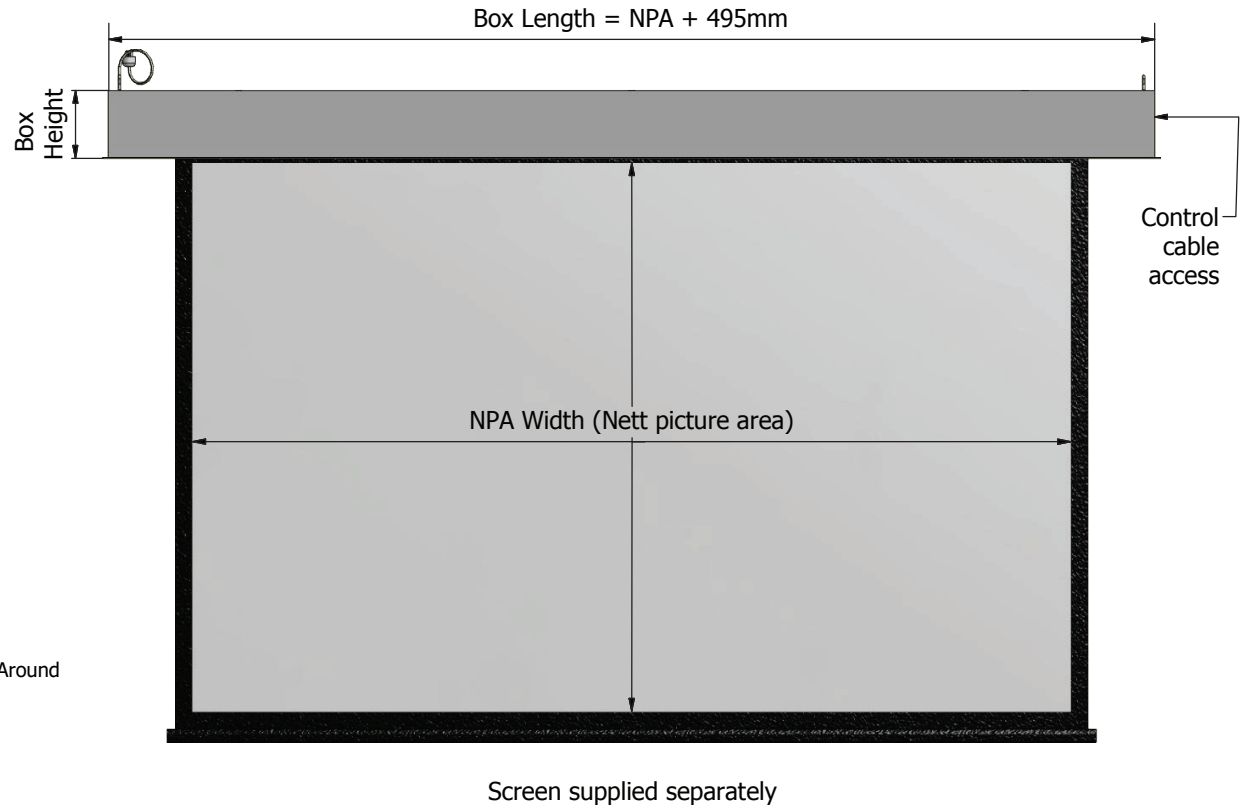
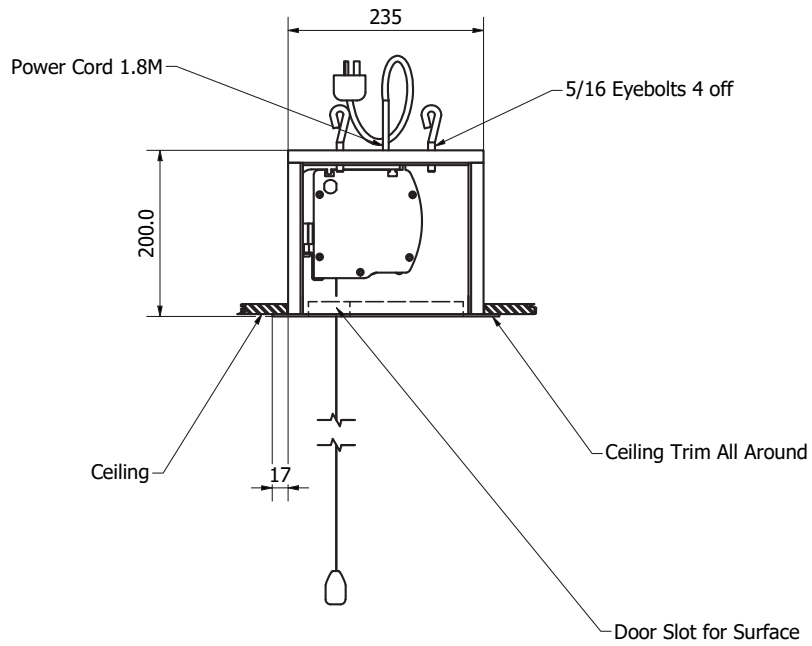

Manufacturing tolerance +/- 5mm. All dimensions are in (mm).
Always allow for removal of screen for servicing.

The Concept, Design and Details in this drawing are the property of Screen Technics with whom the copyright resides. They may not be reproduced without written permission of Screen Technics.

Date
04/11/2019

Rev
03

Product Features

DESCRIPTION:

In-Ceiling installation with power junction and brackets system

BOX:

E0 MDF Construction with fully painted Low VOC 2 pack white underside & ceiling edge covers for easy install. Custom colours available.

SCREEN:

Suitable only for ElectriCinema Range of Screens

INSTALLATION:

Utilising 5/16" threaded holes with either brooker rod or eye bolts to suitable structure

BRACKETS:

Utilises brackets supplied with ElectriCinema Screen

SIZES:

As shown - Custom Sizes & Formats available upon request

OPTIONS:

Suitable for Side Tension Systems upon request - size restrictions apply

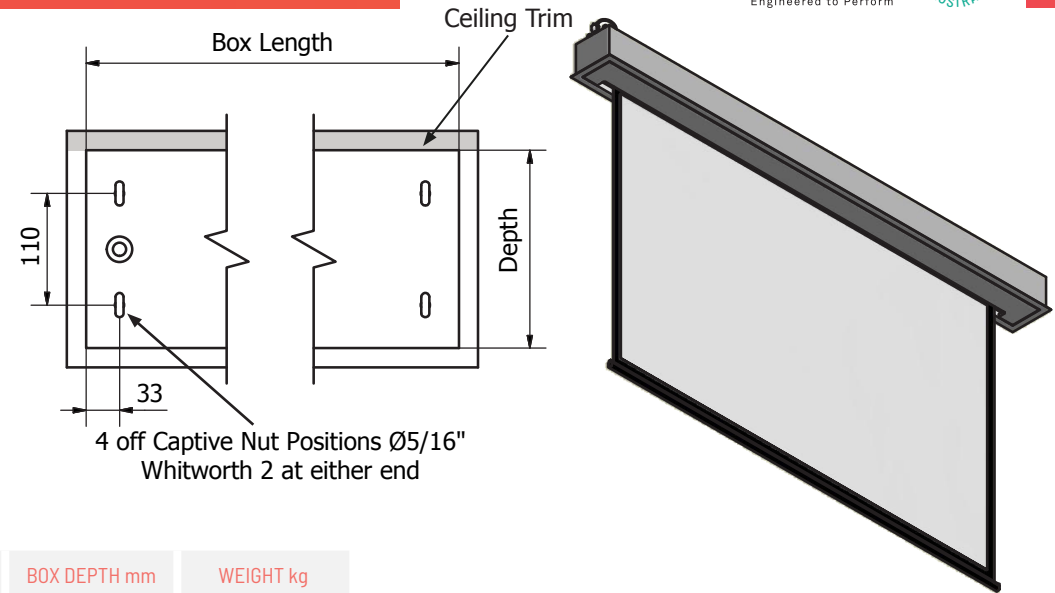

ITEM NO	INCH DIAGONAL	IMAGE SIZE mm	FORMAT	BOX LENGTH mm	BOX HEIGHT mm	BOX DEPTH mm	WEIGHT kg
EB611519-B	115"	1775 x 2340	Video 4:3	2835	200	235	44
EB612019-B	120"	1830 x 2440	Video 4:3	2935	200	235	46
EB613019-B	130"	1980 x 2640	Video 4:3	3135	200	235	49
EB614019-B	140"	2135 x 2845	Video 4:3	3340	200	235	52
EB615019-B	150"	2285 x 3050	Video 4:3	3545	200	235	56
EB611029-B	110"	1370 x 2435	HDTV 16:9	2930	200	235	46
EB611529-B	115"	1430 x 2545	HDTV 16:9	3040	200	235	47
EB612029-B	120"	1495 x 2655	HDTV 16:9	3150	200	235	48
EB613029-B	130"	1615 x 2880	HDTV 16:9	3375	200	235	51
EB614029-B	140"	1740 x 3100	HDTV 16:9	3595	200	235	57
EB615029-B	150"	1865 x 3320	HDTV 16:9	3815	200	235	62
EB611069-B	110"	1480 x 2370	16:10	2865	200	235	45
EB612069-B	120"	1615 x 2585	16:10	3080	200	235	48
EB613069-B	130"	1750 x 2800	16:10	3295	200	235	51
EB614069-B	140"	1885 x 3015	16:10	3510	200	235	57
EB615069-B	150"	2020 x 3230	16:10	3725	200	235	62

ARCHITECTS SPECIFICATION

The screen box shall be an Australian made Screen Technics ElectriCinema Type B model _____ constructed of E Zero MDF and shall be located where indicated on the plans. Installation shall be done in accordance with the manufacturer's instructions



AUSTRALIA

22-24 Suttor Road
Moss Vale NSW 2577
+61 2 4869 2100

NEW ZEALAND

44 Mahana Road
Te Rapa, Hamilton
+0800 022 821

screeentechnics.com.au • info@screeentechnics.com.au

Manufacturing tolerance +/- 5mm. All dimensions are in (mm). Always allow for removal of screen for servicing.