



Interfit Swing Down Flat Panel Screen Lifter

Why not install your flat panel screen horizontally and watch it swing down into position ready for use?

SIZES: TO ACCOMMODATE PANELS 24" - 65"

Providing a unique solution to limited space situations, the Swing Down Interfit Flat Panel Lifter is designed using a single integrated box with ceiling edge cover strips and a fitted door for a simple, modular, single trade installation.

Not enough space to install a Flat Panel Lift vertically in the ceiling? Why not install it horizontally and watch it swing down into position ready for use!

Adjustable to swing up to 25 degrees past the vertical plane, the Swing Down Interfit Flat Panel Screen Lifter ensures Flat Panel visibility for the viewing audience from boardroom to bedroom.

The Interfit Flat Panel Lift Your lifter by choice.

Market Segments:



Home
Entertainment



Education



Corporate

Benefits include:

- Mechanical Lifting Arms
- Fail-Safe Mechanism
- Easy, Single Trade Installation
- Caged one piece unit, utilising nutserts for 'L' Brackets or eyebolts for chain install.



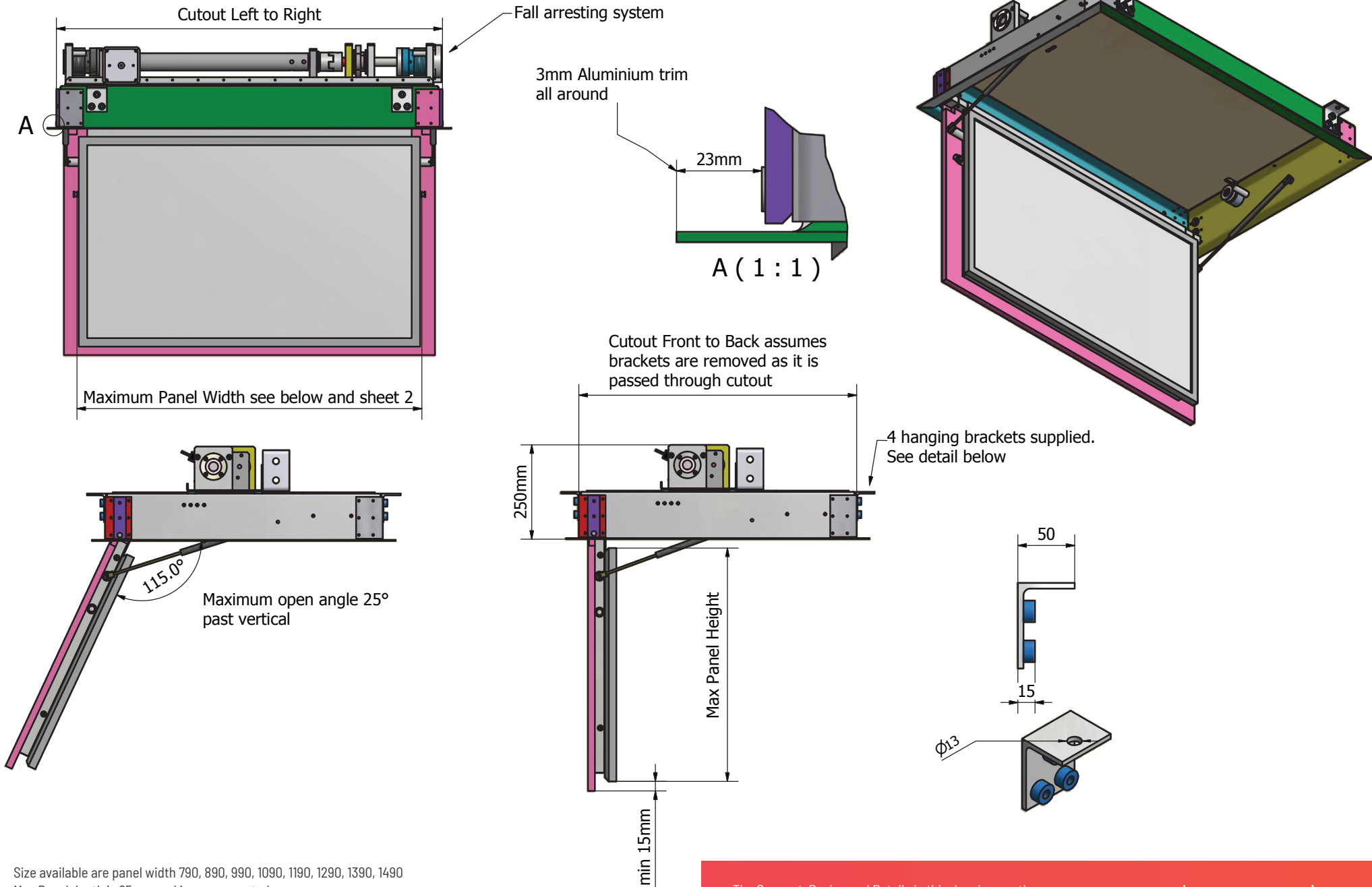

Size available are panel width 790, 890, 990, 1090, 1190, 1290, 1390, 1490
 Max Panel depth is 65mm and is vesa mounted.
 No allowance has been made for adjustable mounting arms

The Concept, Design and Details in this drawing are the property of Screen Technics with whom the copyright resides. They may not be reproduced without written permission of Screen Technics.

Date
25/09/2019

Part Number

Rev
3

PART NUMBER	MAX PANEL WIDTH	MAX PANEL HEIGHT	CUTOUT SIZE LEFT TO RIGHT	CUTOUT SIZE FRONT TO BACK DOES NOT ALLOW FOR BRACKETS	VESA PATTERN
1490800	790mm	500mm	945mm	635mm	200
1490900	890mm	560mm	1045mm	695mm	200
1491000	990mm	615mm	1145mm	750mm	200 300 400
1491100	1090mm	670mm	1245mm	805mm	200 300 400
1491200	1190mm	725mm	1345mm	860mm	200 300 400 600
1491300	1290mm	785mm	1445mm	920mm	200 300 400 600
1491400	1390mm	840mm	1545mm	975mm	200 300 400 600 800
1491500	1490mm	895mm	1645mm	1030mm	200 300 400 600 800

NOTES:

- Maximum Panel depth is 65mm
- Panel is mounted using VESA holes no allowance for arms has been made
- Maximum Panel weight is 50 Kg
- Panel can be adjusted to a maximum of 25° past vertical
- Design has inbuilt fall arresting system

ARCHITECTS SPECIFICATION

The panel lifter shall be an Australian made Screen Technics lifter model _____and shall be located where indicated on the plans. Installation shall be done in accordance with the manufacturer’s instructions



Size available are panel width 790, 890, 990, 1090, 1190, 1290, 1390, 1490
 Max Panel depth is 65mm and is vesa mounted.
 No allowance has been made for adjustable mounting arms

AUSTRALIA	NEW ZEALAND
22-24 Suttor Road	44 Mahana Road
Moss Vale NSW 2577	Te Rapa, Hamilton
+61 2 4869 2100	+0800 022 821