



ViewMaster Pro In-ceiling Screen Box (Australia)

Type 1

A neat and practical in-ceiling solution

SIZES 84" - 115" DIAGONAL

To suit ViewMaster Pro motorised screens.

The ViewMaster Pro Screen Box allows you to install a ViewMaster Pro into the ceiling so that it is out of sight when not in use, but instantly accessible.

ScreenBox

Market Segments:

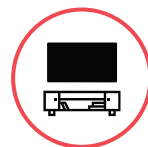

Home Entertainment



Education



Government



Corporate

Benefits include:

- Utilising E Zero MDF
- Underside finished in low VOC 2pk white
- Includes internal power junction for easy and complete AV integration
- Integrated power junction box for electrical connection
- Universal bracketing system for the screen
- Can be pre-fitted during the building construction stage
- Pre-wiring facility
- Maintenance access door
- Single trade installation



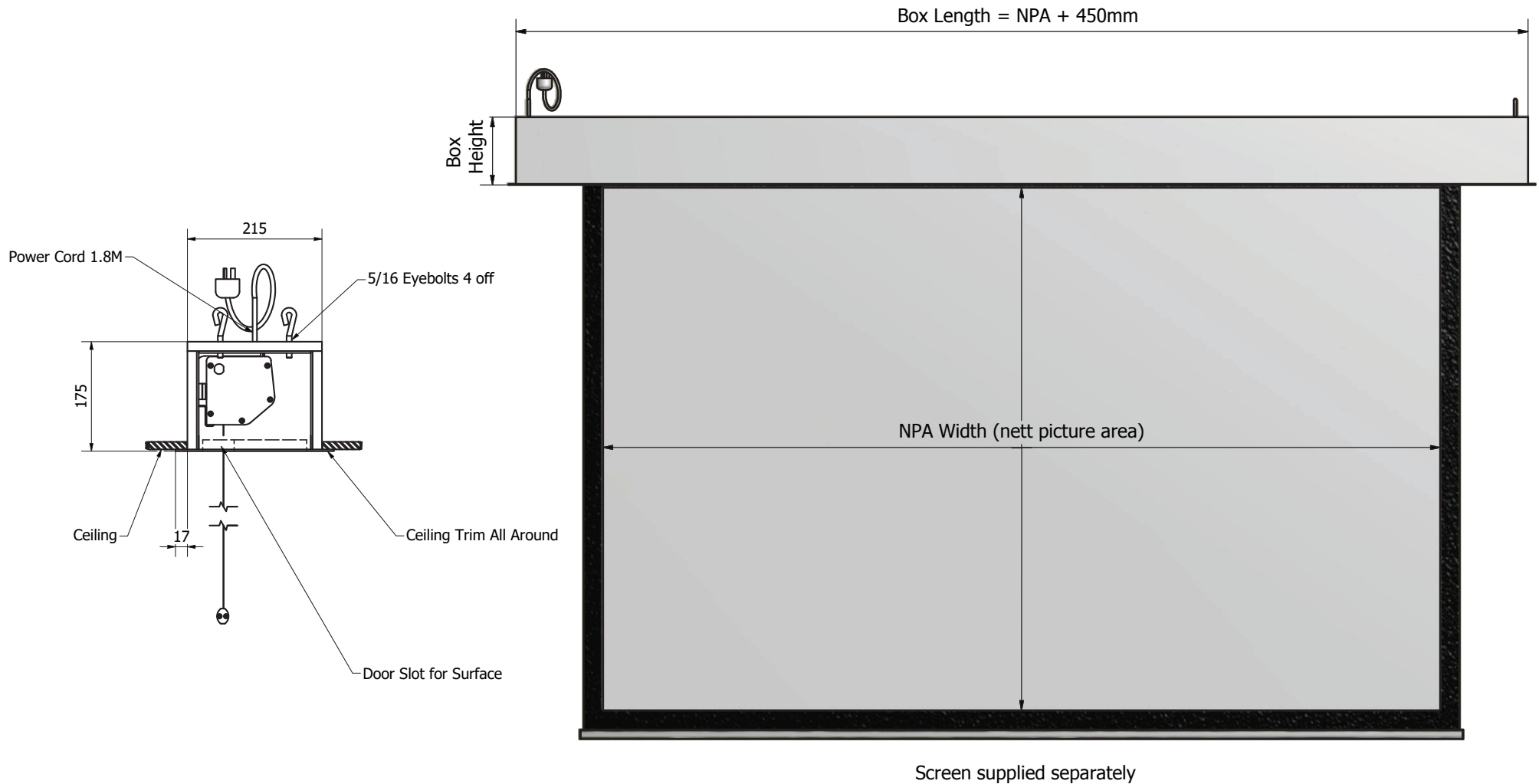

Manufacturing tolerance +/- 5mm
All dimensions are in (mm) If installed in ceiling always allow for removal for servicing.

The Concept, Design and Details in this drawing are the property of Screen Technics with whom the copyright resides. They may not be reproduced without written permission of Screen Technics.

Date
04/11/2019

Part Number
VB45xxxxx-1

Rev
03

Product Features

HEADBOX:
In-Ceiling installation with power junction and bracket system

BOX:
EO Certified MDF construction with fully painted Low VOC 2 pack white underside & ceiling edge covers for easy install. Custom colours available

SCREEN:
Suitable only for the Viewmaster Pro range of screens

INSTALLATION:
Utilising ø5/16 Whitworth threaded holes with either brooker rod or eye bolts to suitable structure

BRACKETS:
Utilises brackets supplied with Viewmaster Pro Screen

SIZES:
As Shown, Custom Sizes & Formats available upon request

ITEM NO	INCH DIAGONAL	IMAGE SIZE mm	FORMAT	BOX LENGTH mm	BOX HEIGHT mm	BOX DEPTH mm	WEIGHT kg
VB4508419-1	84"	1280 x 1705	Video 4:3	2155	175	215	30.0
VB4509619-1	96"	1460 x 1950	Video 4:3	2400	175	215	32.0
VB4510019-1	100"	1525 x 2035	Video 4:3	2485	175	215	33.0
VB4511019-1	110"	1675 x 2235	Video 4:3	2685	175	215	46.0
VB4511519-1	115"	1755 x 2340	Video 4:3	2790	175	215	47.0
VB4508429-1	84"	1045 x 1860	HDTV 16:9	2310	175	215	30.0
VB4508529-1	85"	1060 x 1880	HDTV 16:9	2330	175	215	31.0
VB4509229-1	92"	1145 x 2035	HDTV 16:9	2485	175	215	33.0
VB4509629-1	96"	1195 x 2125	HDTV 16:9	2575	175	215	35.0
VB4510029-1	100"	1245 x 2215	HDTV 16:9	2665	175	215	38.0
VB4510229-1	102"	1270 x 2260	HDTV 16:9	2710	175	215	40.0
VB4511029-1	110"	1370 x 2435	HDTV 16:9	2885	175	215	46.0
VB4511229-1	112"	1395 x 2480	HDTV 16:9	2930	175	215	47.0
VB4508469-1	84"	1130 x 1810	16:10	2260	175	215	30.0
VB4509469-1	94"	1265 x 2025	16:10	2475	175	215	32.0
VB4509669-1	96"	1295 x 2070	16:10	2520	175	215	33.0
VB4510069-1	100"	1345 x 2155	16:10	2605	175	215	35.0
VB4510369-1	103	1385 x 2220	16:10	2670	175	215	37.0
VB4511069-1	110"	1480 x 2370	16:10	2820	175	215	45.0
VB4511569-1	115"	1550 x 2480	16:10	2930	175	215	47.0

Manufacturing tolerance +/- 5mm

All dimensions are in (mm) If installed in ceiling always allow for removal for servicing.

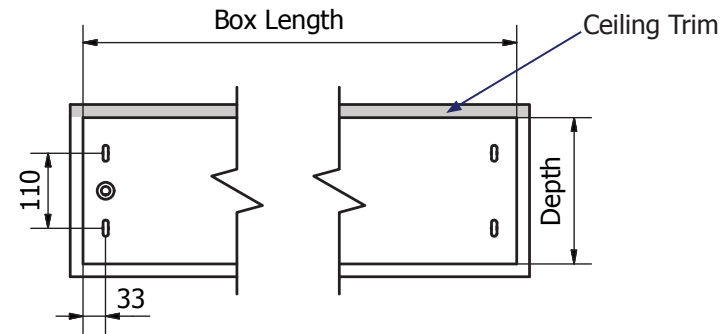
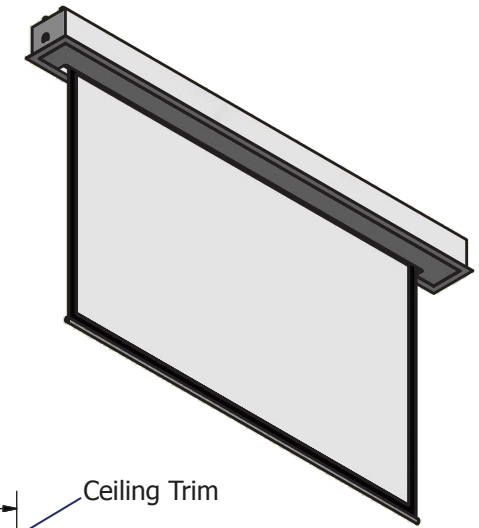

4 off Captive Nut Positions Ø5/16 Whitworth 2 at either end