



## ViewMaster Pro In-ceiling Screen Box (Australia) Type 3

A neat and practical in-ceiling solution

SIZES 160" - 230" DIAGONAL

To suit ViewMaster Pro motorised screens.

The ViewMaster Pro Screen Box allows you to install a ViewMaster Pro into the ceiling so that it is out of sight when not in use, but instantly accessible.

ScreenBox

### Market Segments:

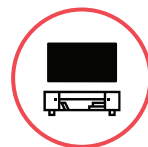

Home Entertainment



Education



Government



Corporate

### Benefits include:

- Utilising E Zero MDF
- Underside finished in low VOC 2pk white
- Includes internal power junction for easy and complete AV integration
- Integrated power junction box for electrical connection
- Universal bracketing system for the screen
- Can be pre-fitted during the building construction stage
- Pre-wiring facility
- Maintenance access door
- Single trade installation



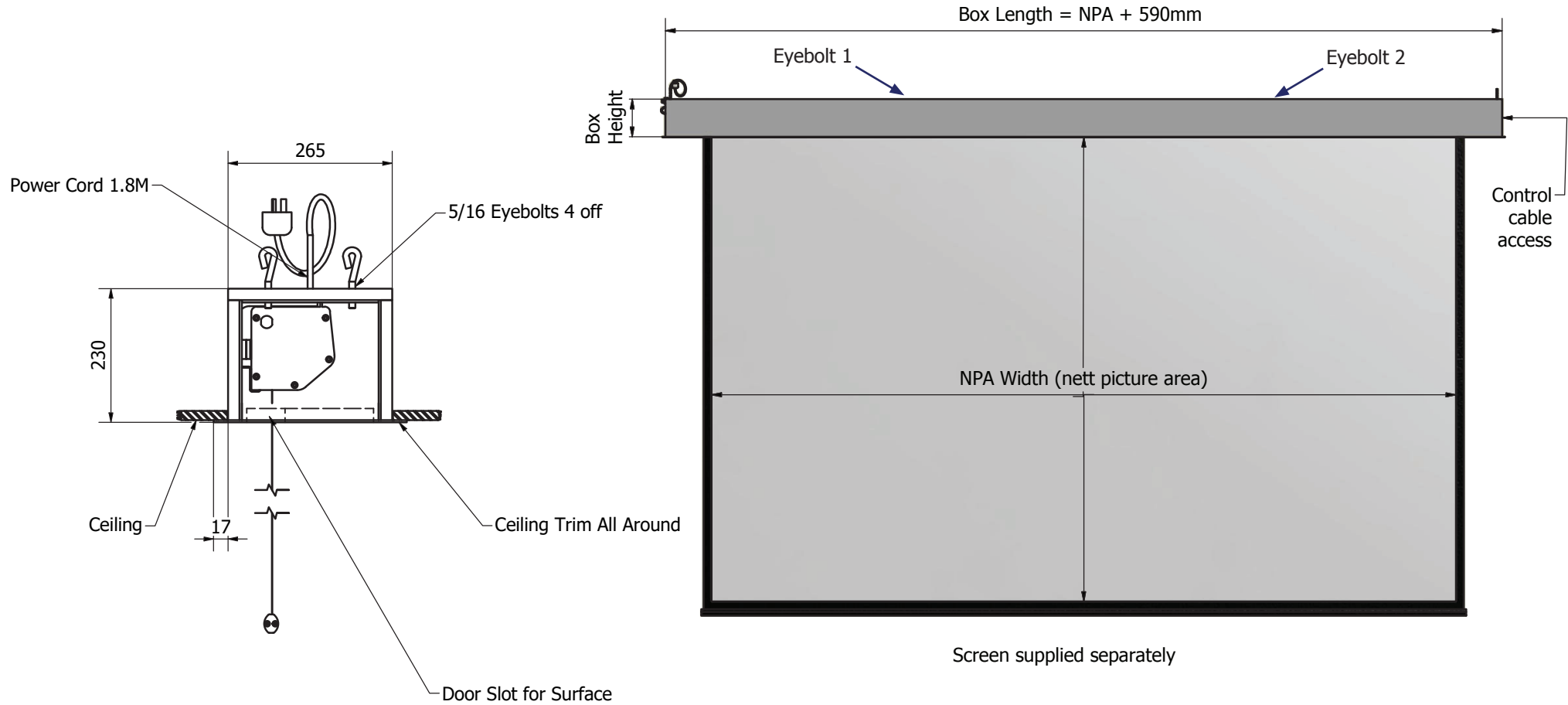

Manufacturing tolerance +/- 5mm  
All dimensions are in (mm) If installed in ceiling always allow for removal for servicing.

The Concept, Design and Details in this drawing are the property of Screen Technics with whom the copyright resides. They may not be reproduced without written permission of Screen Technics.

Date  
28/04/2021

Part Number  
VB45xxxxx-3

Rev  
04

**Product Features**

**HEADBOX:**  
In-Ceiling installation with power junction and bracket system

**BOX:**  
EO MDF Construction with fully painted Low VOC 2 pack white underside & ceiling edge covers for easy install. Custom colours available.

**SCREEN:**  
Suitable only for the Viewmaster Pro range of screens

**INSTALLATION:**  
Utilising ø5/16 Whitworth threaded holes with either brooker rod or eye bolts to suitable structure

**BRACKETS:**  
Utilises brackets supplied with Viewmaster Pro Screen

**SIZES:**  
As Shown, Custom Sizes & Formats available upon request

ITEM NO	INCH DIAGONAL	IMAGE SIZE mm	FORMAT	BOX LENGTH mm	BOX HEIGHT mm	BOX DEPTH mm	WEIGHT kg
VB4516019-3	160"	2440 x 3250	Video 4:3	3840	230	265	76
VB4517019-3	170"	2590 x 3445	Video 4:3	4035	230	265	80
VB4518019-3	180"	2745 x 3660	Video 4:3	4250	230	265	84
VB4519019-3	190"	2895 x 3860	Video 4:3	4450	230	265	88
VB4520019-3	200"	3050 x 4065	Video 4:3	4655	230	265	92
VB4521019-3	210"	3200 x 4265	Video 4:3	4855	230	265	95
VB4522019-3	220"	3355 x 4470	Video 4:3	5060	230	265	100
VB4523019-3	230"	3505 x 4675	Video 4:3	5265	230	265	103
VB4516029-3	160"	1995 x 3545	HDTV 16:9	4135	230	265	82
VB4517029-3	170"	2115 x 3765	HDTV 16:9	4355	230	265	85
VB4518029-3	180"	2240 x 3985	HDTV 16:9	4575	230	265	90
VB4519029-3	190"	2365 x 4205	HDTV 16:9	4795	230	265	95
VB4520029-3	200"	2490 x 4425	HDTV 16:9	5015	230	265	100
VB4521029-3	210"	2615 x 4650	HDTV 16:9	5240	230	265	105
VB4522029-3	220"	2740 x 4870	HDTV 16:9	5460	230	265	107
VB4516069-3	160"	2155 x 3450	16:10	4040	230	265	80
VB4517069-3	170"	2290 x 3665	16:10	4255	230	265	84
VB4518069-3	180"	2425 x 3880	16:10	4470	230	265	88
VB4519069-3	190"	2560 x 4095	16:10	4685	230	265	92
VB4520069-3	200"	2695 x 4310	16:10	4900	230	265	96
VB4521069-3	210"	2830 x 4525	16:10	5115	230	265	102
VB4522069-3	220"	2695 x 4740	16:10	5330	230	265	105

Manufacturing tolerance +/- 5mm  
All dimensions are in (mm) If installed in ceiling always allow for removal for servicing.

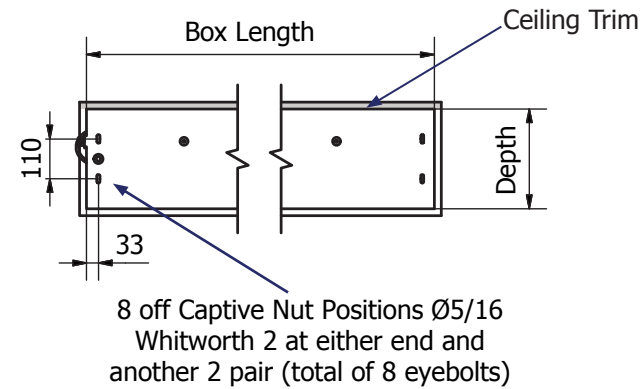
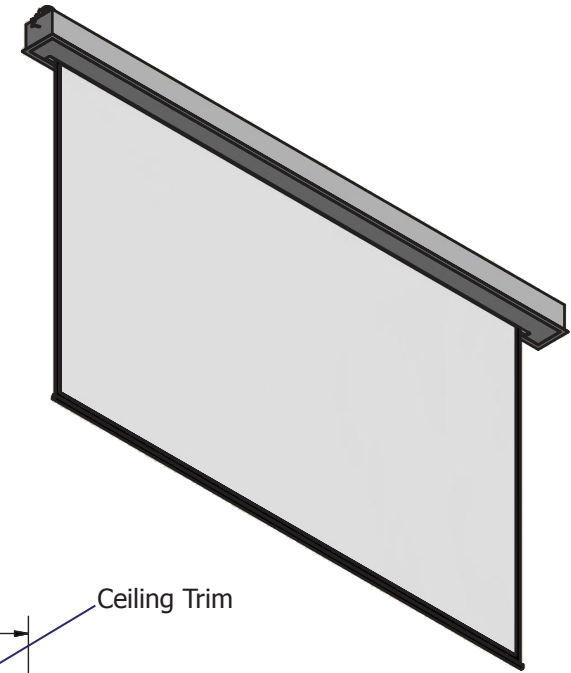

**ARCHITECTS SPECIFICATION**  
The screen box shall be an Australian made Screen Technics ViewMaster Pro Type 3 model \_\_\_\_\_ constructed of E Zero MDF and shall be located where indicated on the plans. Installation shall be done in accordance with the manufacturer’s instructions.



AUSTRALIA

22-24 Suttor Road  
Moss Vale NSW 2577  
+61 2 4869 2100

NEW ZEALAND

44 Mahana Road  
Te Rapa, Hamilton  
+0800 022 821